

Steca Solsum

2525, 4040

Solar charge controllers Steca Solsum 2525 and 4040 are newly developed products based on our internationally renowned controller family Solarix PRS. With increased module and load current, the controllers are now also suitable for even larger systems. The devices also feature an integrated USB charging port for charging smartphones and tablets. The controllers demonstrate impressive performance, are simple to use and offer unbeatable value for money.

Several LEDs in various colours give information on the battery's state of charge. Here, Steca's latest algorithms are employed, resulting in optimal battery maintenance. The Steca Solsum charge controllers are equipped with an electronic fuse, thus making optimal protection possible. They operate on the serial principle, and separate the solar module from the battery in order to protect it against overcharging.

For larger projects, the charge controllers can also be equipped with special functions: e.g. with night light function and selectable charging plateau and deep-discharge protection voltages.

BASIC



Product features

- Serial topology with MOSFETs
- Automatic detection of voltage
- Voltage regulation
- PWM control
- Multistage charging technology
- Current compensated load disconnection
- Automatic load reconnection
- Temperature compensation
- Negative earthing of one or positive earthing of several terminals possible
- Monthly equalisation charge
- USB charge socket for smartphones and tablets

Electronic protection functions

- Overcharge protection
- Deep discharge protection
- Reverse polarity protection of module (≤ 36 V), load and battery
- Automatic electronic fuse
- Short circuit protection of load and module
- Overvoltage protection at module input
- Open circuit protection without battery
- Reverse current protection at night
- Overtemperature and overload protection
- Load disconnection on battery overvoltage

Displays

- Multifunction LED display
- Multi-coloured LED
- 4 LEDs show operating states
- for operation, state of charge, fault messages

Options

- Evening or night light function pre-set in the factory or adjustable via Steca PA RC 100
- Parameterisation of function values via Steca PA RC 100

Certificates

- Compliant with European Standards (CE)
- RoHS compliant
- Made in EU
- Manufactured according to ISO 9001 and ISO 14001

Accessories

- Steca PA RC100

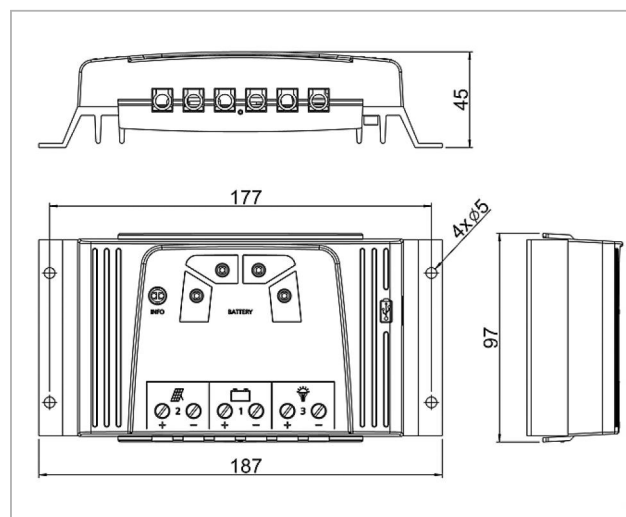

	2525	4040
Characterisation of the operating performance		
System voltage	12 V (24 V)	
Own consumption	< 10,5 mA	
DC input side		
Open circuit voltage solar module (at minimum operating temperature)	< 47 V	
Module current	25 A	40 A
DC output side		
Load current	25 A	40 A
USB charge socket	5.2 V / 1.5 A	
Reconnection voltage (LVR)	12.4 V ... 12.7 V (24.8 V ... 25.4 V)	
Deep discharge protection (LVD)	11.2 V ... 11.6 V (22.4 V ... 23.2 V)	
Battery side		
Battery voltage	9 V ... 17 V (17.1 V ... 34 V)	
End-of-charge voltage	13.9 V (27.8 V)	
Boost charge voltage	14.4 V (28.8 V)	
Equalisation charge	14.7 V (29.4 V)	
Set battery type	liquid	
Operating conditions		
Ambient temperature	-25 °C ... +50 °C	
Fitting and construction		
Terminal (fine / single wire)	16 mm ² / 25 mm ² - AWG 6 / 4	
Degree of protection	IP 30	
Dimensions (X x Y x Z)	187 x 97 x 45 mm	
Weight	345 g	

- Technical data at 25 °C / 77 °F
- adjustable via Steca PA RC100: reconnection voltage, deep discharge protection, end of charge voltage, boost charge voltage, equalisation charge, battery type
- Inverters must not be connected to the load output.